

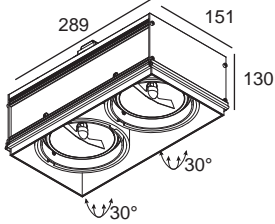

**GRID IN LIMIT ZB 1 QR ANO**  
**202 65 00 01 ANO**  
G53 / 12V / EXCL. TRANSFO  
1x QR-LP111 35-50-75-100W

ORIENTABLE 0°-30°

**GRID IN LIMIT ZB 2 QR ANO**  
**202 65 00 02 ANO**  
G53 / 12V / EXCL. TRANSFO  
2x QR-LP111 35-50-75-100W

ORIENTABLE 0°-30°



ACCESSORIES / OPTIONS:

GRID IN LIMIT+ FRONTGLASS OR  
COLOUR FILTER OR LENS = MAX. 50W

**FRONTGLASS 111**  
201 17 00

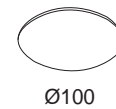

**COLOUR FILTER 111**  
201 27 11 (BLUE)  
201 27 12 (GREEN)  
201 27 13 (RED)  
201 27 14 (YELLOW)

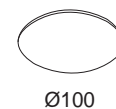

**LENS 111**  
201 47 11

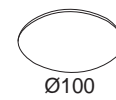

**CONE 111**  
201 28 00 ALU  
201 28 00 B  
201 28 00 C  
201 28 00 W

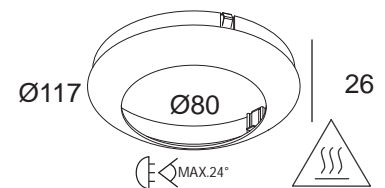

**GRID IN LIMIT ZB 1 QR BOX**  
202 65 98 01

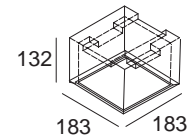

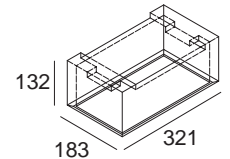

**GRID IN LIMIT ZB 2 QR BOX**  
202 65 98 02





**WAARSCHUWING** Lees de algemene gebruiksvoorwaarden : **DEEL B**  
**AVERTISSEMENT** Lire attentivement les conditions générales d'utilisation : **PARTIE B**  
**WARNUNG** Lesen Sie die allgemeinen Gebrauchsanweisungen : **TEIL B**  
**WARNING** Read the general directions : **PART B**  
**AMMONIZIONE** Leggere attentamente le condizioni generali di utilizzazione : **PARTE B**  
**EDVERTENCIA** Leer atentamente las condiciones generales de uso : **PARTE B**



 Enkel geschikt voor toestellen op zeer lage spanning (minder dan 50 V AC)  
Convient uniquement pour les produits à très basse tension (moins de 50 V AC)  
Geeignet für Güter mit sehr niedriger Spannung (unter 50 V AC)  
Only suited for goods at very low voltage (below 50 V AC)  
Se recomienda únicamente para aquellos productos de tensión muy baja (menos de 50 V AC)  
Vale unicamente per i prodotti a tensione molto bassa (inferiore a 50 V AC)

 Verlichtingstoestellen die ontworpen zijn om alleen gebruikt te worden met zelfbeschermende halogeen wolframlampen  
Luminaires conçus pour être utilisés uniquement avec des lampes tungstène halogène autoprotégées  
Lampen, die nur zur Verwendung mit Tungsten-Halogenlampen konzipiert und  
Luminaires designed for use with self-shielded tungsten halogen lamps only  
Luminarias diseñadas para ser utilizadas únicamente con lámparas de tungsteno halógeno autoprotegidas  
Apparecchi di illuminazione per l'uso unicamente con lampade al tungsteno alogene

 Minimum afstand van de verlichte voorwerpen (meter)  
Distance minimale par rapport aux objets éclairés (mètres)  
Mindestabstand von beleuchteten Gegenständen (Meter)  
Minimum distance from lighted objects (metres)  
Distancia mínima de los objetos iluminados (metros)  
Distanza min. dagli oggetti illuminati (metri)

 Installeer het armatuur enkel in ruimten waar direct contact met water onmogelijk is.  
Cet équipement doit être installé dans des pièces hors de toute projection d'eau.  
Diese Leuchte darf nur in Räumen verwendet werden, in denen ein direkter Kontakt mit Wasser nicht möglich ist  
This fitting should only be installed in rooms where direct contact with water is impossible  
Este aparato solamente puede ser instalado en habitaciones donde el contacto directo con el agua sea imposible  
Questo apparecchio di illuminazione deve essere installato solamente in locali in cui il contatto con l'acqua è impossibile.

 Max. stralingshoek  
Max. angle d'ouverture  
Max. austrahlungswinkel  
Max. beam angle  
Max. Apertura de haz  
Max. apertura fascio luminoso

IP 20 Beschermd tegen vaste voorwerpen die groter zijn dan 12 mm  
Protégé contre les objets solides de plus de 12 mm  
Geschützt gegen Festkörper größer als 12 mm  
Protected against solid objects greater than 12 mm  
Protegido contra objetos sólidos superiores a 12 mm  
Protetto contro oggetti solidi più grandi di 12 mm

850°C Gloeitest  
Fil incandescent  
Glowtest  
Glühtest  
Ensayo de recocido  
Filo incandescente

 Bevestiging wand + plafond inbouw  
Montage mur + plafond encastré  
Montage wand + decke eingebaut  
Fixation wall + ceiling recessed  
Montaje pared + techo empotrado  
Montaggio parete + soffitto incasso

 Opgepast warm oppervlak - niet aanraken - buiten bereik installeren  
Attention surface de contact chaude - ne pas toucher - installer hors d'atteinte  
Achtung heiße Oberfläche - Nicht Berühren - Nur unerreichbar installieren  
Caution hot surface - do not touch - install out of reach  
Precaución alta temperatura de la superficie - no tocar - instalar fuera de alcance  
Attenzione superficie calda - non toccare - installare in luogo non accessibile

**GRID IN LIMIT ZB 1 QR ANO**  
**GRID IN LIMIT ZB 2 QR ANO**

**INSTALLATION INSTRUCTIONS - PART A**

**GRID IN LIMIT 1**

01  
 MAKE A RESERVATION IN THE CEILING AND USE THE OPTION **GRID IN LIMIT ZB 1 QR BOX**

185 x 185 x 135

**HOLE PATTERN**

**GRID IN LIMIT 2**

01  
 MAKE A RESERVATION IN THE CEILING AND USE THE OPTION **GRID IN LIMIT ZB 2 QR BOX**

323 x 185 x 135

**HOLE PATTERN**

01. MAKE HOLE PATTERN
02. MAKE THE ELECTRICAL CONNECTION
03. PLACE THE DEVICE
04. INSERT/REPLACE LAMP
05. SWITCH ON

